

Spring 2023

# Spring Maker News



Coiling Equipment Newsletter



## PRODUCT FOCUS



## BEM-CNC

### Wire Bending and Forming

#### Wire Bending Machines features:

- **Easy and Fast Wire Forming Production of Round Wire**
- Strip material can also be formed using optional accessories
- **Programing is fast and accurate**
- **High Resolution Touch Screen control unit** with big, clear command buttons makes it easy to load and save programs
- **Push Button control** starts each bending action
- **Variable Speed control** can be adjusted from 1% to 100%
- **Production Menu is** very intuitive. It shows:
  - ⇒ Progress Indicator
  - ⇒ Current Position Indication
  - ⇒ Sample Counter



Production Screen

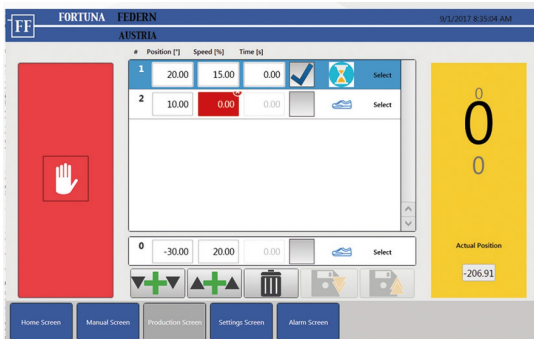

Manual Screen

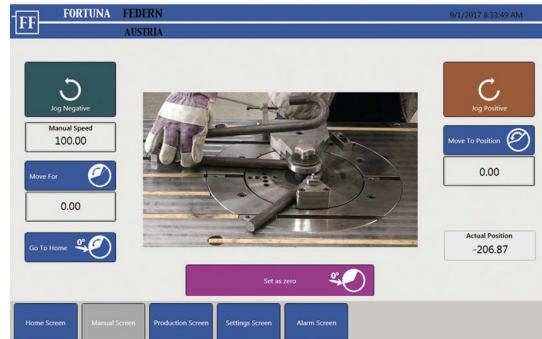

Programming is quick and accurate using the touch control screen. It is easy to load and save programs.

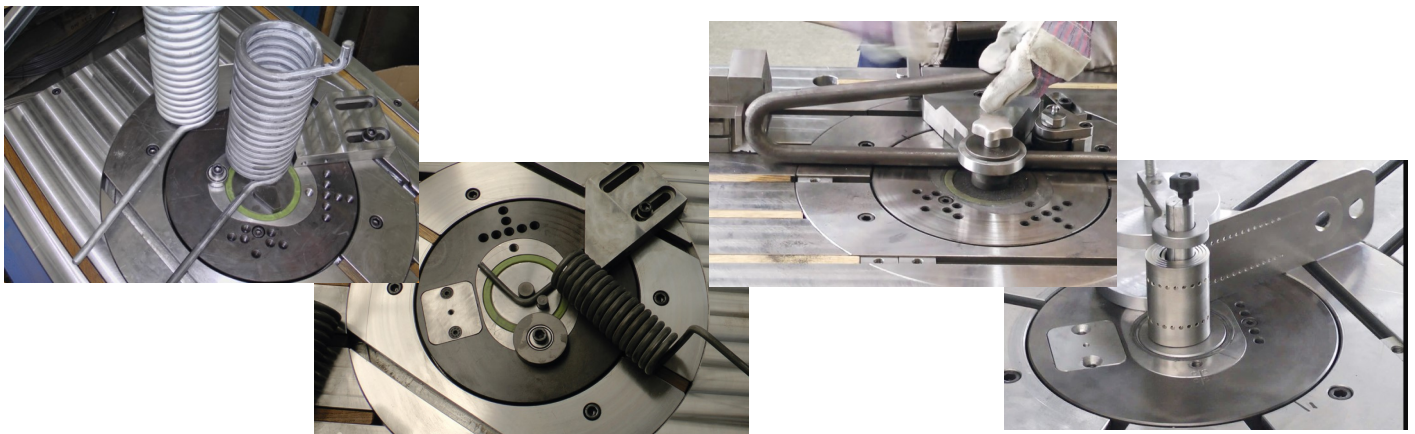

Spring 2023

# Spring Maker News

## PRODUCT FOCUS

**FF** FORTUNA FEDERN  
AUSTRIA

### BEM-CNC Wire Bending Machines, Music Wire from 4 mm to 20 mm

Model	BEM-12	BEM-14	BEM-16	BEM-20
Wire diameter acc. to EN 10270-1 DH ph (ASTM A228 Music Wire - ca. 1300 N/mm <sup>2</sup> )	4 - 12 mm * .157" - .472"	5 - 14 mm * .197" - .551"	6 - 16 mm * .236" - .629"	6 - 20 mm * .236" - .787"
Max. wire diameter of soft wire (p.E. 50CrV4)	15 mm * .590"	18 mm * .708"	22 mm * .866"	24 mm * .944"
Productivity	ca. 1,000 bends 360° per hour	ca. 600 bends 360° per hour	ca. 600 bends 360° per hour	ca. 600 bends 360° per hour
Drive by	servo	servo	servo	servo
Accessoires incl. the price	Set of standard bending tools			
Consumption	4 kW 3 x 400V / 50Hz	5 kW 3 x 400V / 50Hz	7 kW 3 x 400V / 50Hz	8 kW 3 x 400V/50Hz
Weight	550 kg 1,212 lbs	600 kg 1,322 lbs	700 kg 1,543 lbs	900 kg 1,984 lbs
Dimensions (L x W x H)	1.1 x 0.9 x 1 m 3.6 x 2.9 x 3.2 ft	1 x 1.3 x 1 m 3.2 x 4.2 x 3.2 ft	1 x 1.3 x 1 m 3.2 x 4.2 x 3.2 ft	1 x 1.3 x 1 m 3.2 x 4.2 x 3.2 ft

\* depends of the bent radius

#### BEM CNC Video



Scan QR Code to see the BEM Machine video



<https://vimeo.com/145616796>

#### BEM Standard Set of bending tools

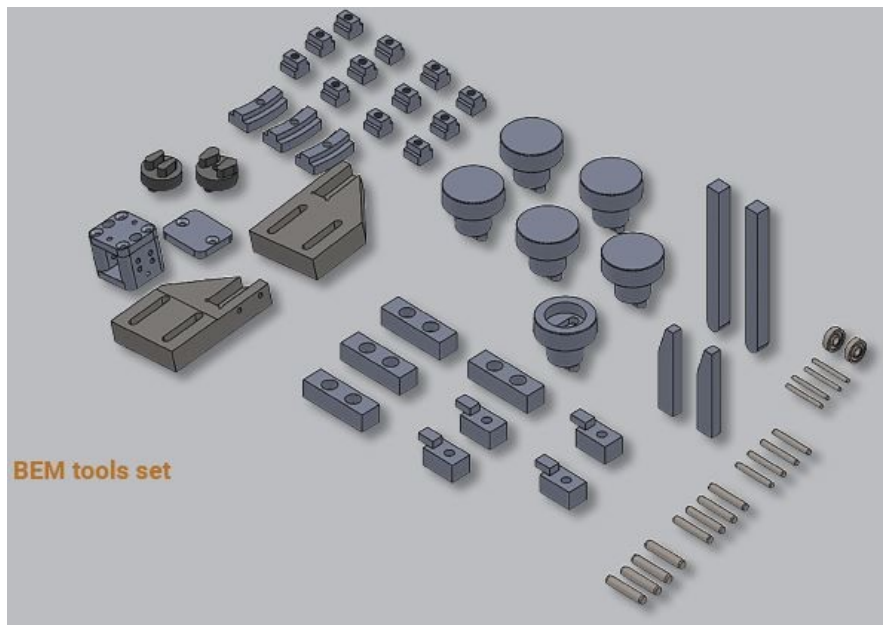

Spring 2023

# Spring Maker News



Coiling Equipment Newsletter



## PRODUCT FOCUS



## OBW / MPK Looping Machines



### Looping Machines features:

- **Easy Production of single German (machine) loops on pre-coiled spring**
- **Standard Set of Tooling**
- **Setup DVD included** with each machine makes it easy for the operator to quickly learn how to operate and make loops with the machine
- **Looping Machines will work with Music Wire Diameter** ranging from 0.8 mm to 20 mm and a spring outer diameter from 5 mm to 240 mm

OBW-2 Manual Looper



OBW - 2  
manual device  
(symbol picture)

Scan QR Code to see the OBW-2 and  
OBW-6 Machine video



<https://vimeo.com/145616805>

OBW-4 Electric Looper



OBW - 4  
(symbol picture)

OBW-8 Electric Looper



OBW - 8

Spring 2023

# Spring Maker News

## PRODUCT FOCUS



**Looping Machines handle wire diameter from 0.8 mm to 20 mm and spring outer diameter from 5 mm to 240 mm**

Model	OBW-2	OBW-4	OBW-6	OBW-8	MPK-12	MPK-16	MPK-20
Wire diameter acc. to EN 10270-1 DH ph (ASTM A228 Music Wire - ca. 1300 N/mm <sup>2</sup> )	0.8 - 2 mm .0314" - .0787"	2 - 4 mm .0787" - .157"	3 - 6 mm .118" - .236"	4 - 8 mm .157" - .315"	5 - 12 mm .197" - .472"	7 - 16 mm .276" - .630"	8 - 20 mm .315" - .787"
Spring outer diameter	5 - 24 mm .197" - .944"	10 - 41 mm .393" - 1.614"	15 - 62 mm .591" - 2.441"	22 - 90 mm .866" - 3.543"	25 - 150 mm .984" - 5.905"	35 - 180 mm 1.378" - 7.086"	40 - 240 mm 1.575" - 9.449"
Loop type	German (machine) English	German (machine)	German (machine)	German (machine)	German (machine)	German (machine)	German (machine)
Loop height	from 0.4 to 1x MD	from 0.4 to 1x MD	from 0.4 to 1x MD	from 0.4 to 1.2x MD	from 0.4 to 1x MD	from 0.4 to 1x MD	from 0.4 to 1x MD
Driven by	manual	electric motor	electric motor	electric motor	hydraulic	hydraulic	hydraulic
Size	0.5 x 0.2 x 0.05 m 1.6 x 0.6 x 0.16 ft	0.3 x 0.5 x 0.6 m 1 x 1.6 x 2 ft	0.4 x 0.6 x 0.7 m 1.3 x 2 x 2.3 ft	0.6 x 0.7 x 1 m 2 x 2.3 x 3.3 ft	1 x 1 x 1.8 m 3.3 x 3.3 x 5.9 ft	1 x 1 x 1.8 m 3.3 x 3.3 x 5.9 ft	1 x 1.6 x 2 m 3.3 x 5.2 x 6.6 ft
Weight	6 kg 13 lbs	50 kg 110 lbs	80 kg 176 lbs	250 kg 550 lbs	600 kg 1,320 lbs	800 kg 1,760 lbs	1,300 kg 2,860 lbs
Consumption	-	1.5 kW 3 x 400V / 50Hz	1.5 kW 3 x 400V / 50Hz	2.2 kW 3 x 400V / 50Hz	4 kW 3 x 400V / 50Hz	4 kW 3 x 400V / 50Hz	4 kW 3 x 400V / 50Hz

<https://vimeo.com/145616803>

### MPK-16 Hydraulic Looper

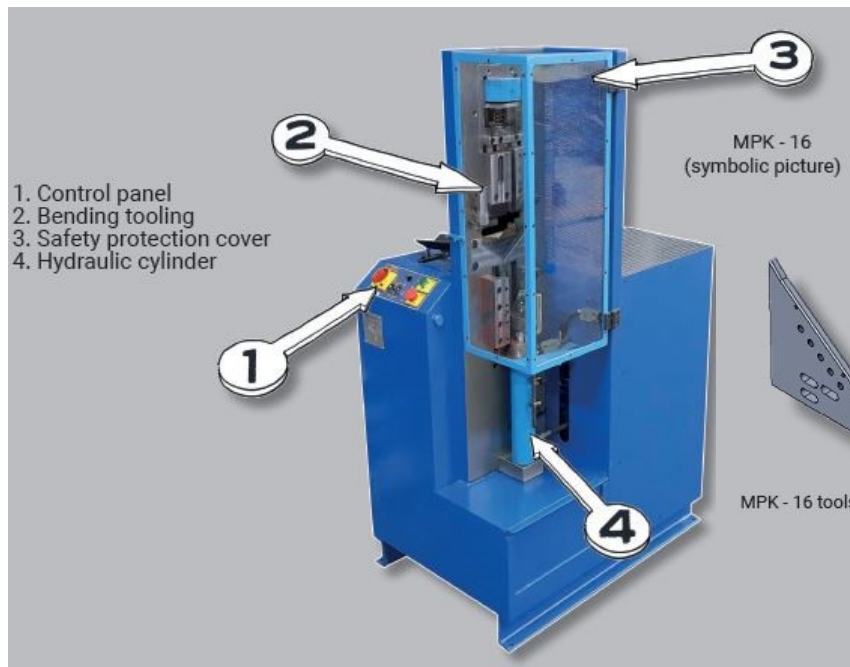

Scan QR Code to see the MPK-20 Hydraulic Looping Machine video

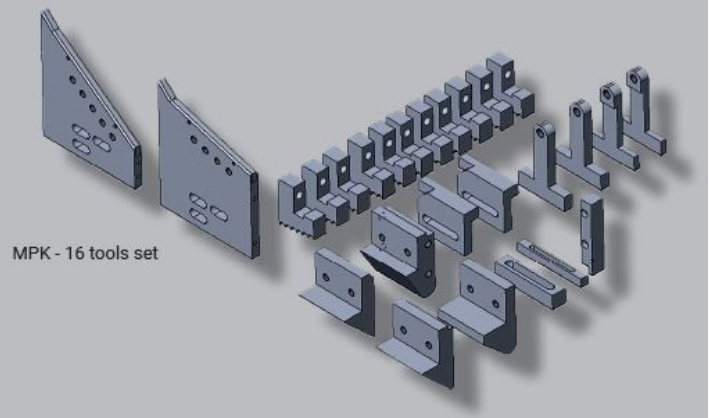

Spring 2023

# Spring Maker News



## Fast Response

Time is important when you have an issue or a need!



Gerry Wright Al Uzumcu

We take pride in getting you an answer quickly when you contact us.

Whether you are looking for a replacement part, have a technical question or need a quote on the right machine for your spring making needs—we are ready to get you a timely response.

Go to our website, email or call Al or Gerry directly.

**Al Uzumcu:**

al@coilingequipment.com

Cell: 847-910-7348

**Gerry Wright:**

gerry@coilingequipment.com

Cell: 847-525-8891

<https://coilingequipment.com/>

Your Fast Response Team



## Many machines and options are available



COM-CNC Series – Spring Coiling Machines

• Designed for production of compression, extension, conical (one or both sides) springs and rings

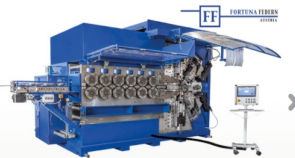

WIM-CNC Series – Spring Lathe Coiling Machines

Automatic servo controlled for COLD production of right and left coiled cylindrical, one side conical compression, extension and torsion springs, different wire forms and double torsion springs



Wire Bending & Forming Machine



Easy production for bending and wire forming

[Learn More](#)

Spring Looper Machines



Manual and electric spring looping machines

[Learn More](#)

Hydraulic Spring Looper Machines



Heavy duty spring hook forming machines

[Learn More](#)



Spring Trimming Machines



Designed for trimming springs

[Learn More](#)

Spring End Grinder Machines



Flat end grinding for compression springs

[Learn More](#)

Power Reels



Right and left-hand power reels

[Learn More](#)



Coiling Machinery



Parts & Tooling



Coiling Machinery



Parts & Tooling

[https://coilingequipment.com](https://coilingequipment.com/) — Al Uzumcu Phone: 847-910-7348

Gerry Wright Phone: 847-525-8891